EMISSION CONTROL SYSTEM

CONTENTS

1. SPECIFICATIONS	17A-1-1
GENERAL SPECIFICATIONS	17A-1-1
SERVICE SPECIFICATIONS	17A-1-1
TORQUE SPECIFICATIONS	17A-1-2
SEALANTS	17A-1-2
2. PARTS LOCATION	17A-2-1
3. INSPECTION	17A-3-1
POSITIVE CRANKCASE VENTILATION VALVE	17A-3-1
EGR VALVE	17A-3-1
THERMO VALVE	17A-3-2
COOLANT TEMPERATURE SENSOR	17A-3-2

1. SPECIFICATIONS

GENERAL SPECIFICATIONS

Positive crankcase ventilation valve	Variable flow-rate type
EGR valve	Single type
Thermo valve	Bimetal type
Oxygen sensor	Zirconia sensor type
(vehicles with catalytic converter only)	
Coolant temperature sensor	Thermistor type

NOTE

The emission control systems differ in their specifications depending on the model and destination. From the emission control parts listed in the GENERAL SPECIFICATIONS, the optimum ones have been selected and installed. Refer to the Workshop Manuals of specific models, therefore, for the description of parts that have been mounted.

SERVICE SPECIFICATIONS

EGR valve

Valve closing check pressure	2.7 kPa (20 mmHg, 0.8 inHg)
Valve opening check pressure	40 kPa (300 mmHg, 12 inHg)

Thermo valve

Valve opening check temperature	10°C (50°F) or lower
Valve closing check temperature	80°C (176°F) or higher

Coolant temperature sensor

Resistance	
At 0°C (32°F)	5.9 kΩ (Oval type connector) 5.8 kΩ (Square type connector)
At 20°C (68°F)	2.5 kΩ (Oval type connector) 2.4 kΩ (Square type connector)
At 40°C (104°F)	1.1 kΩ
At 80°C (176°F)	0.3 kΩ

TORQUE SPECIFICATIONS

	Nm	Torque kgm	ft.lbs.
Positive crankcase ventilation valve	10	1.0	7.3
EGR valve attaching bolt	22	2.2	16
Thermo valve	30	3.0	21.7
Oxygen sensor	45	4.5	32.5
Coolant temperature sensor	30	3.0	21.7

SEALANTS

	Specified sealant	Quantity
Thermo valve threaded part	3M Nut Locking Part No. 4171 or equivalent	As required
Coolant temperature sensor threaded part	3M Nut Locking Part No. 4171 or equivalent	As required

2. PARTS LOCATION

4G15 and 4G37

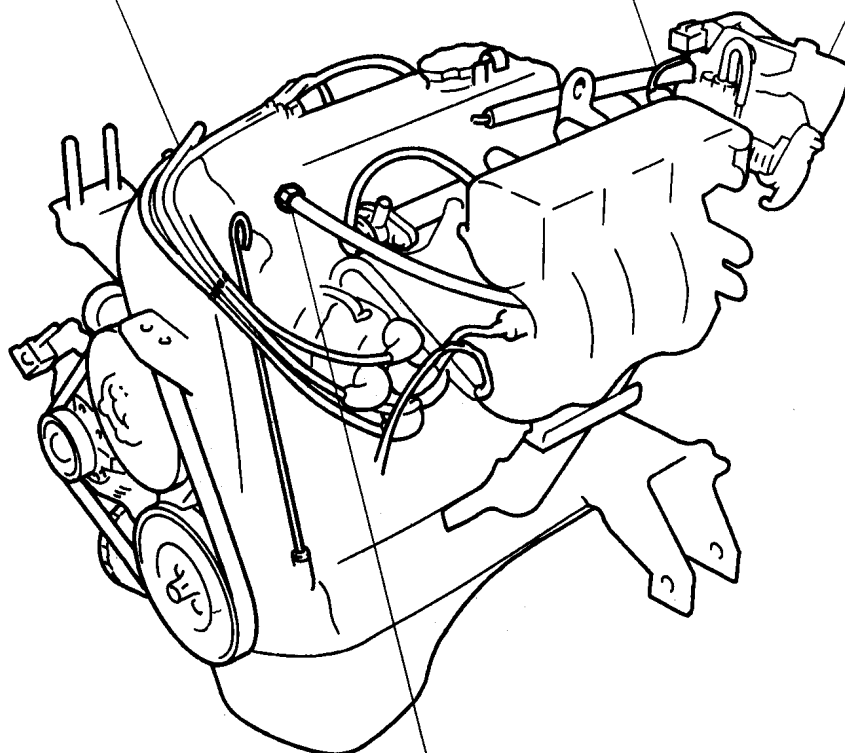
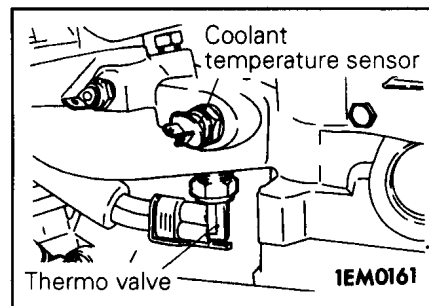
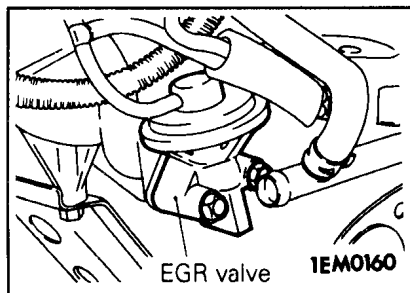
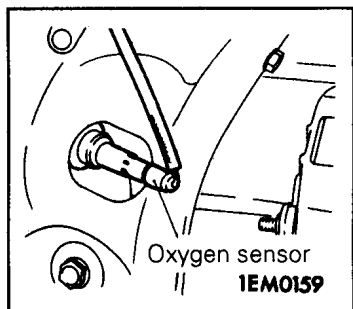

4G63, 4G64

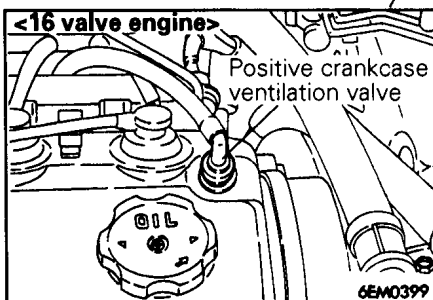
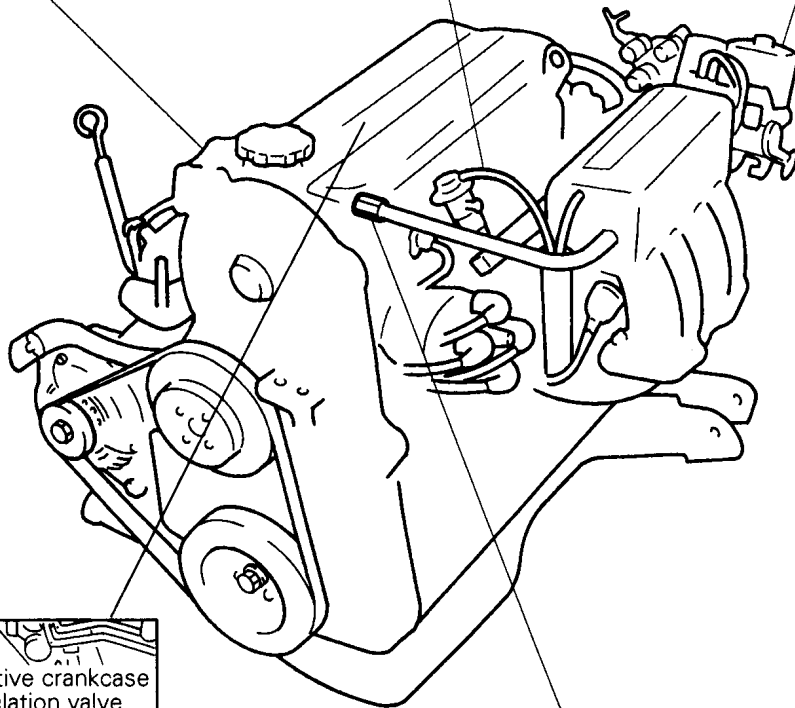
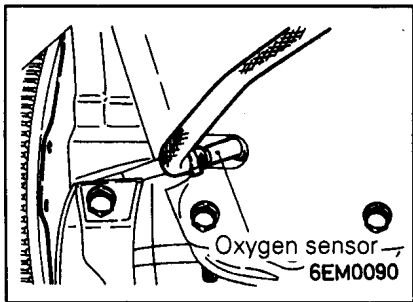
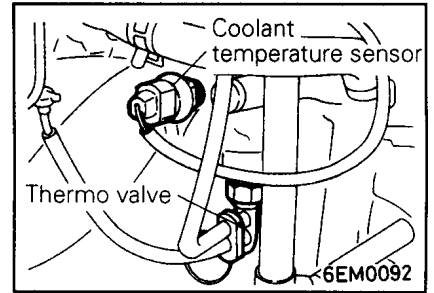
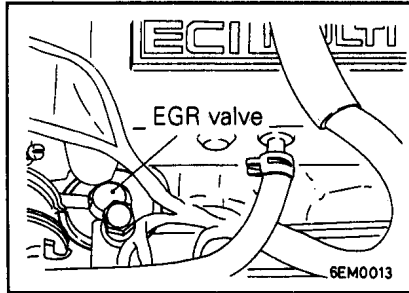

Positive crankcase ventilation valve <8 valve engine>

4G61 4G67 4G63

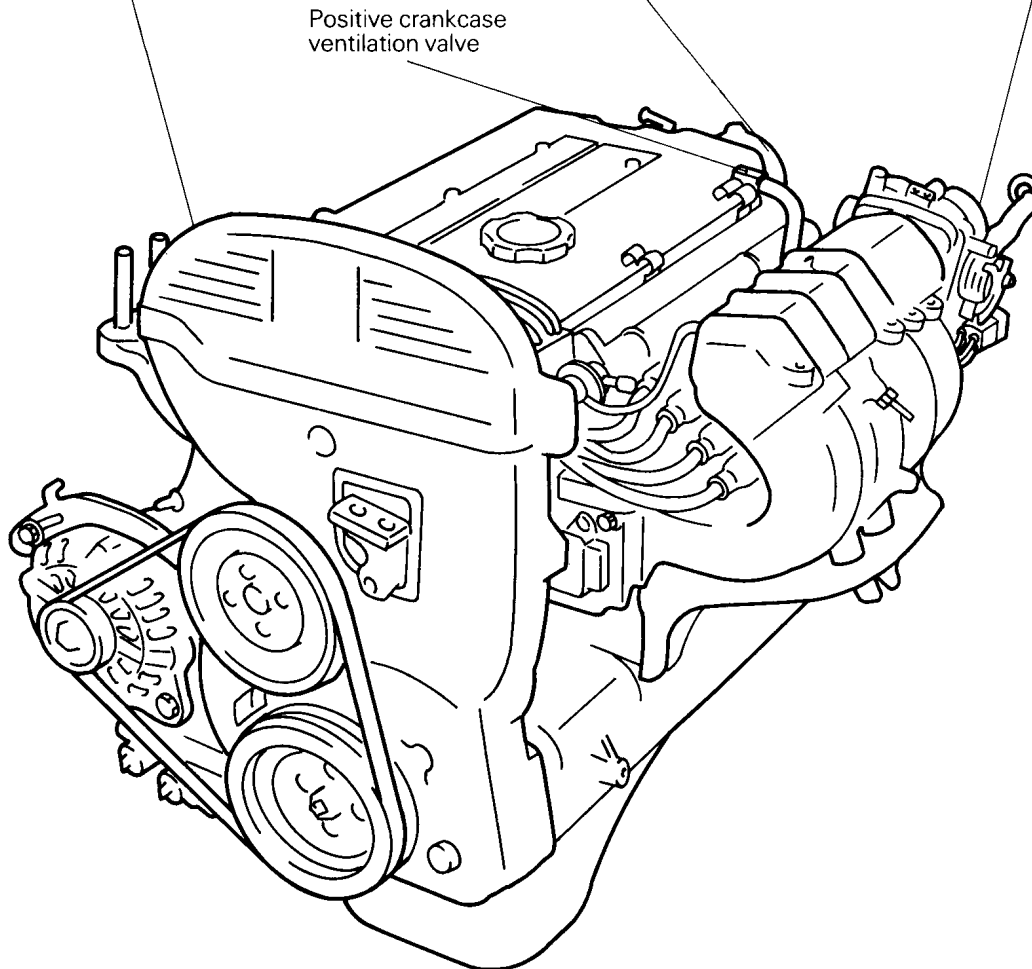
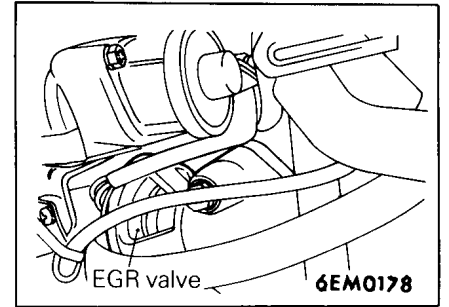
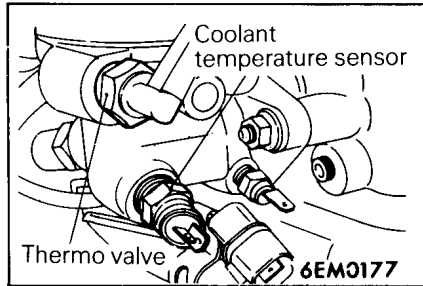
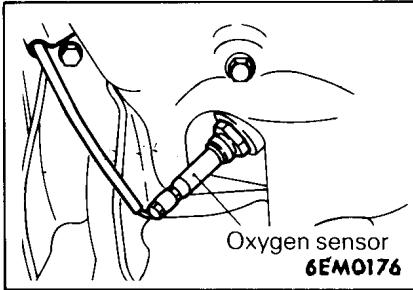

6EM0175

6G72 (Pajero)

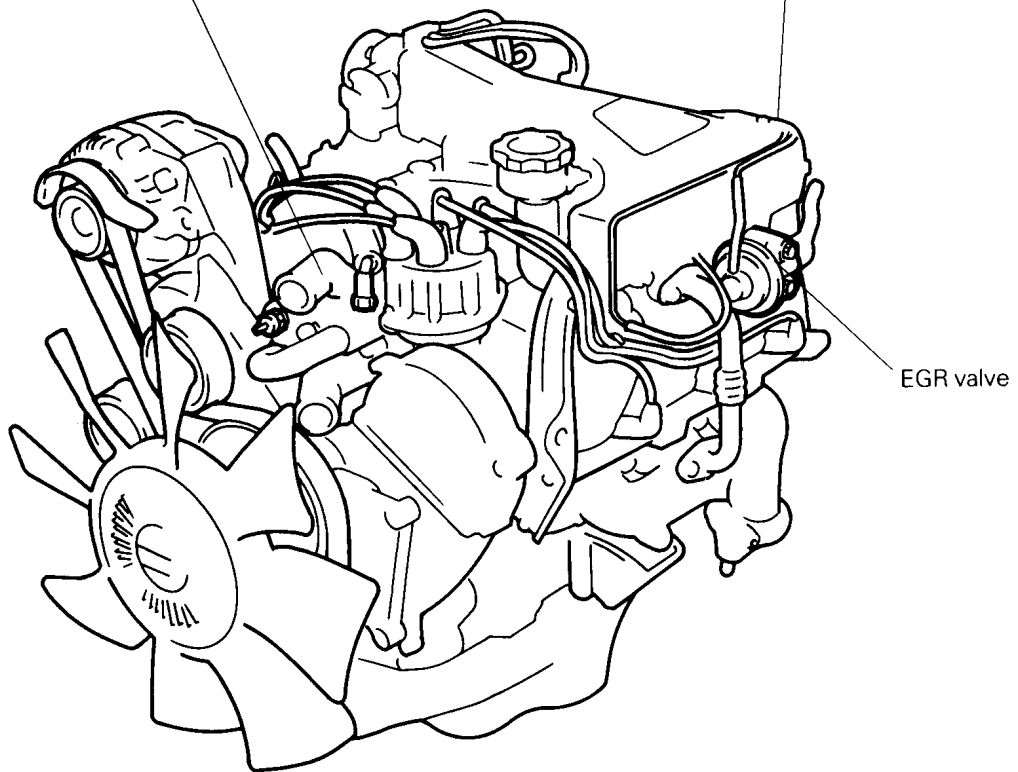
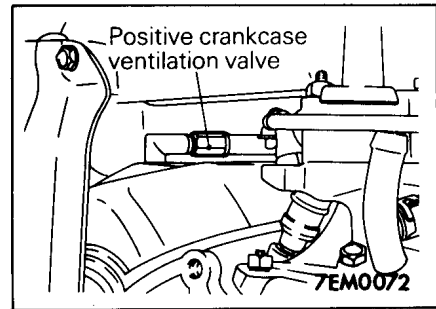
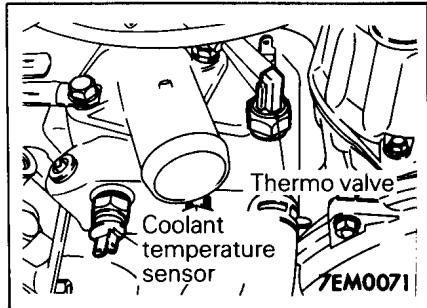

4G92 and 4G93 (SOHC)

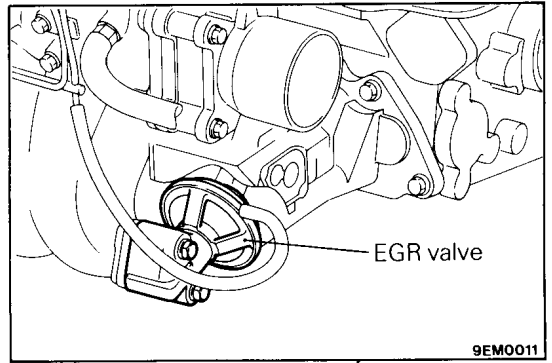
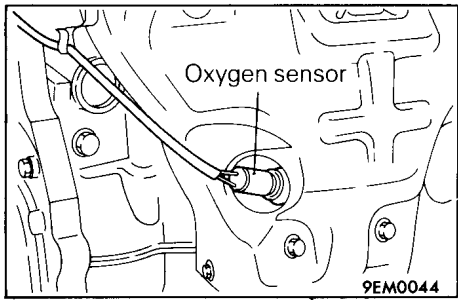
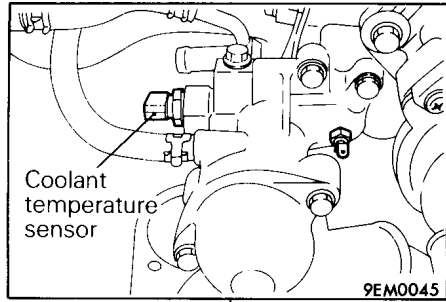

Positive crankcase ventilation valve

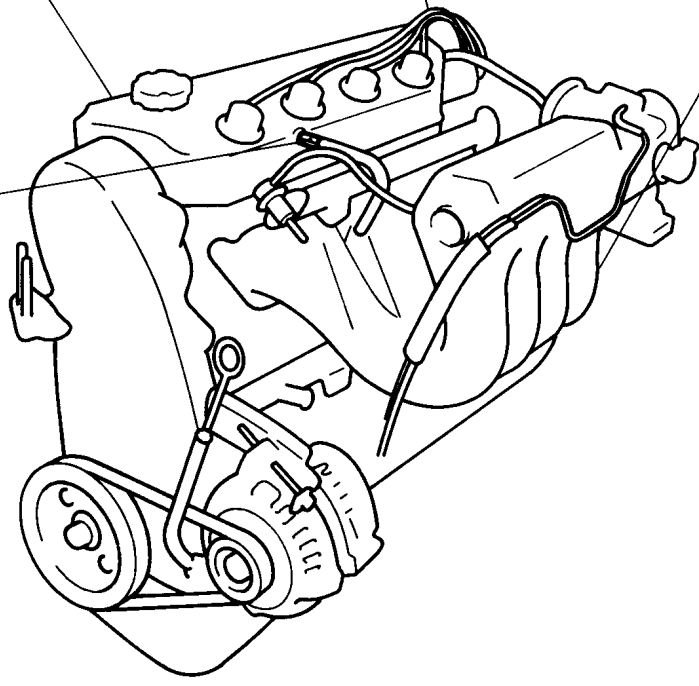

6G72-SOHC (Diamante, Sigma)

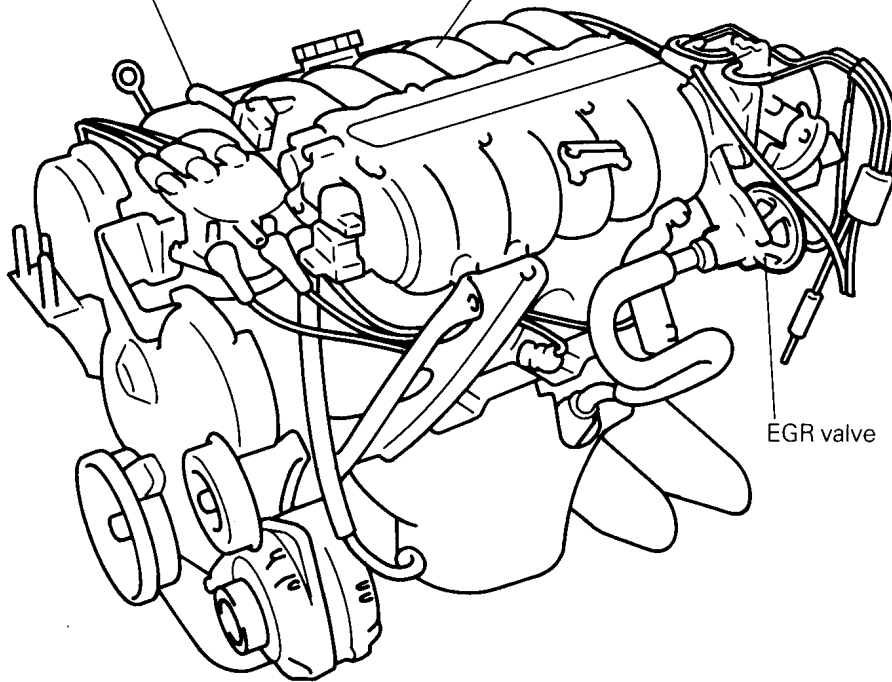
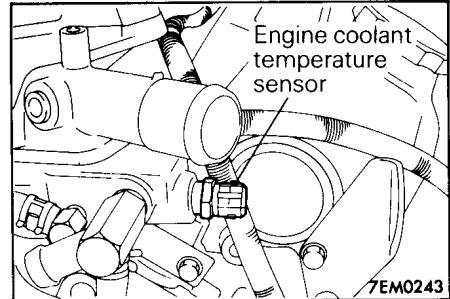
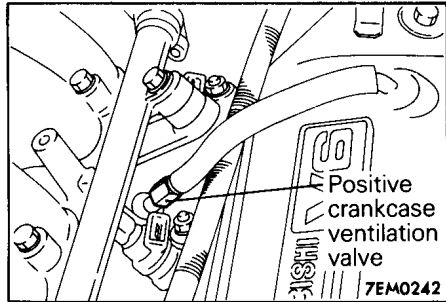

6G72-DOHC (Diamante, Sigma, 3000GT), 6G73 and 6A12-DOHC (Galant)

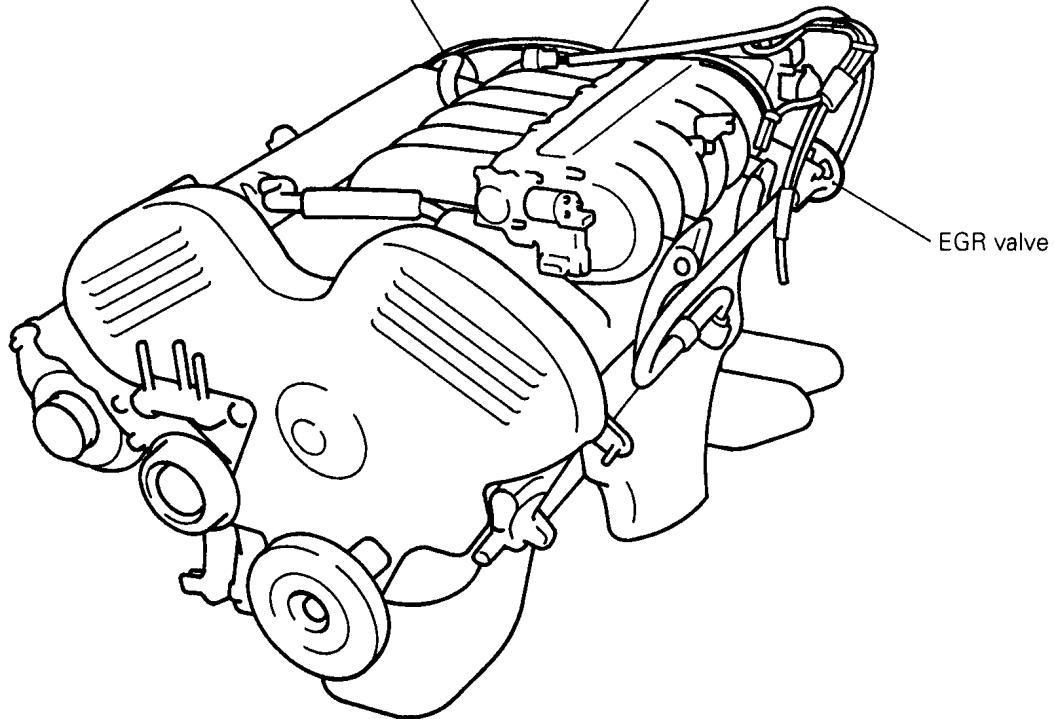
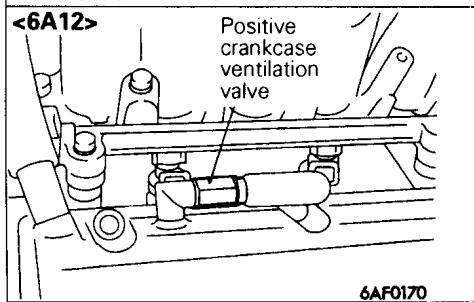
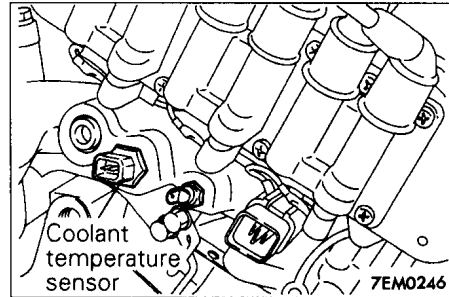
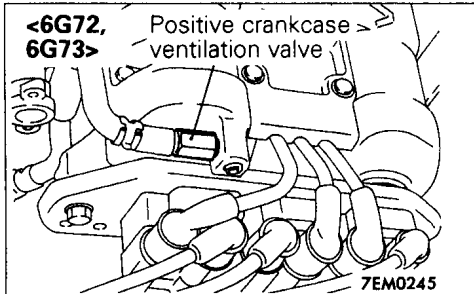

4G13

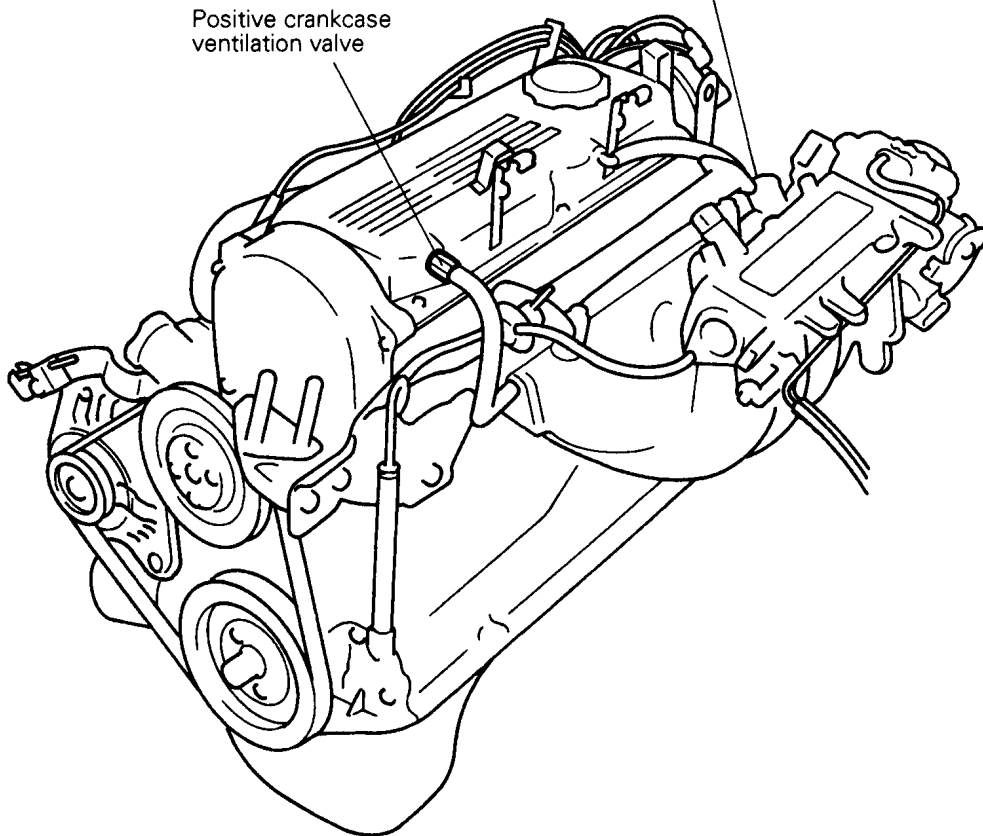
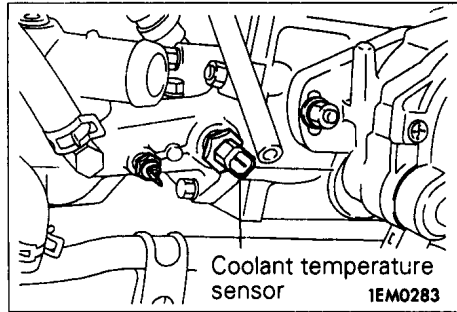

1EM0282

4G93 (DOHC), 4G91

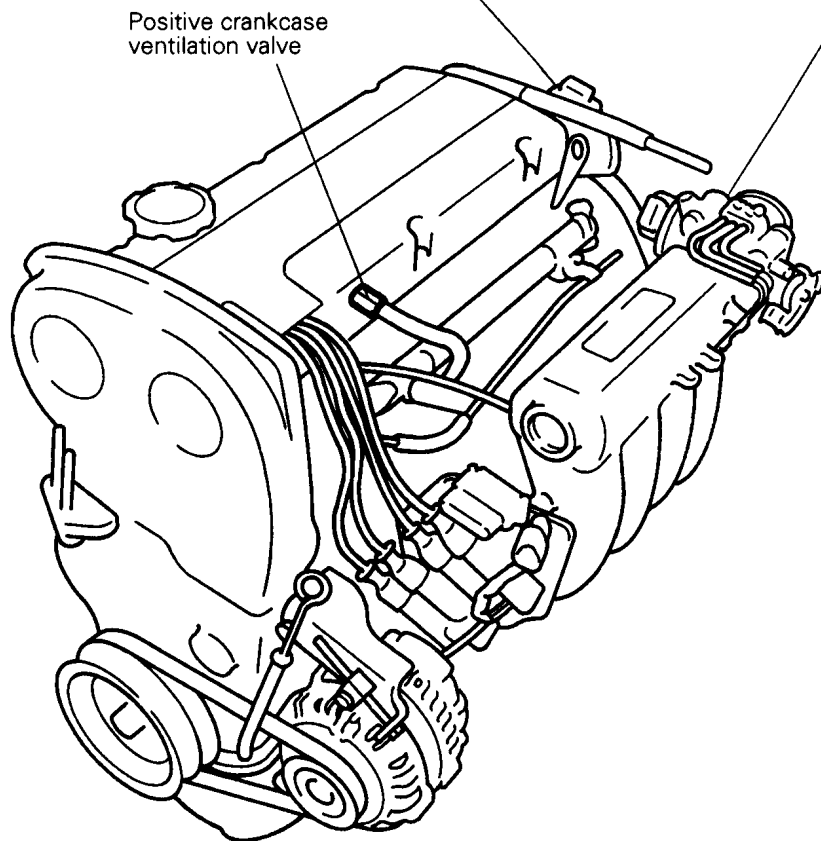
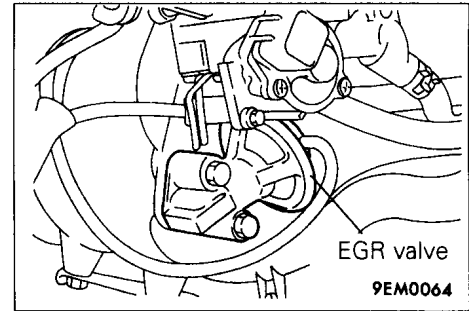
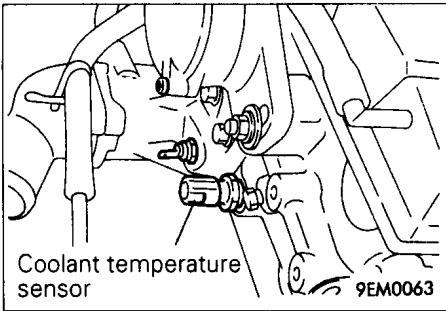

9EM0062

6G74

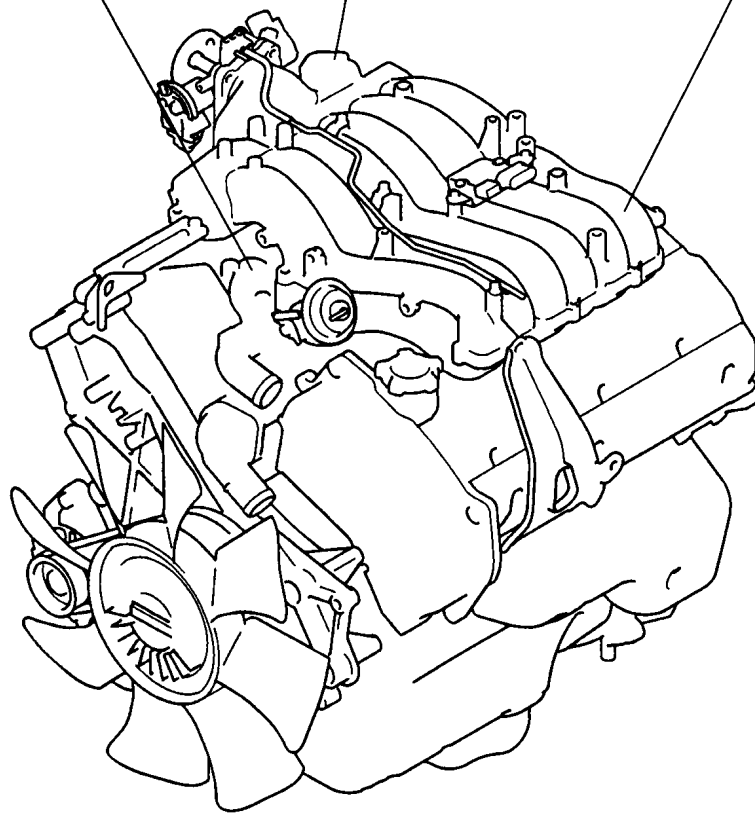
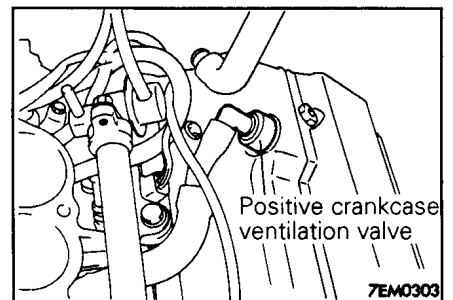
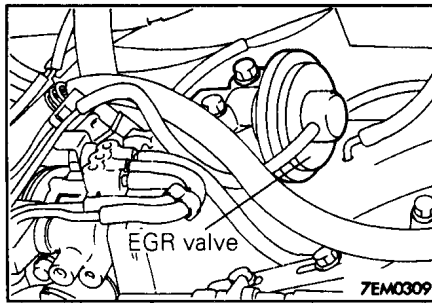
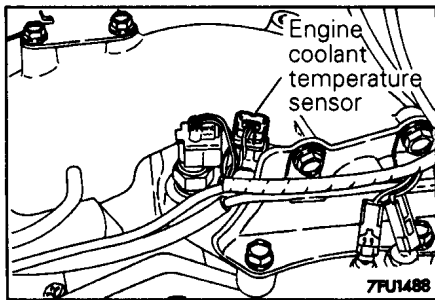

6G72 – SOHC 24-VALVE (L400 and Pajero/Montero)

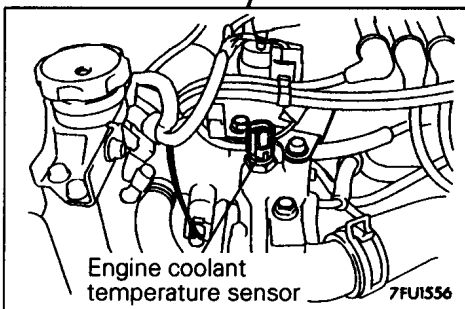
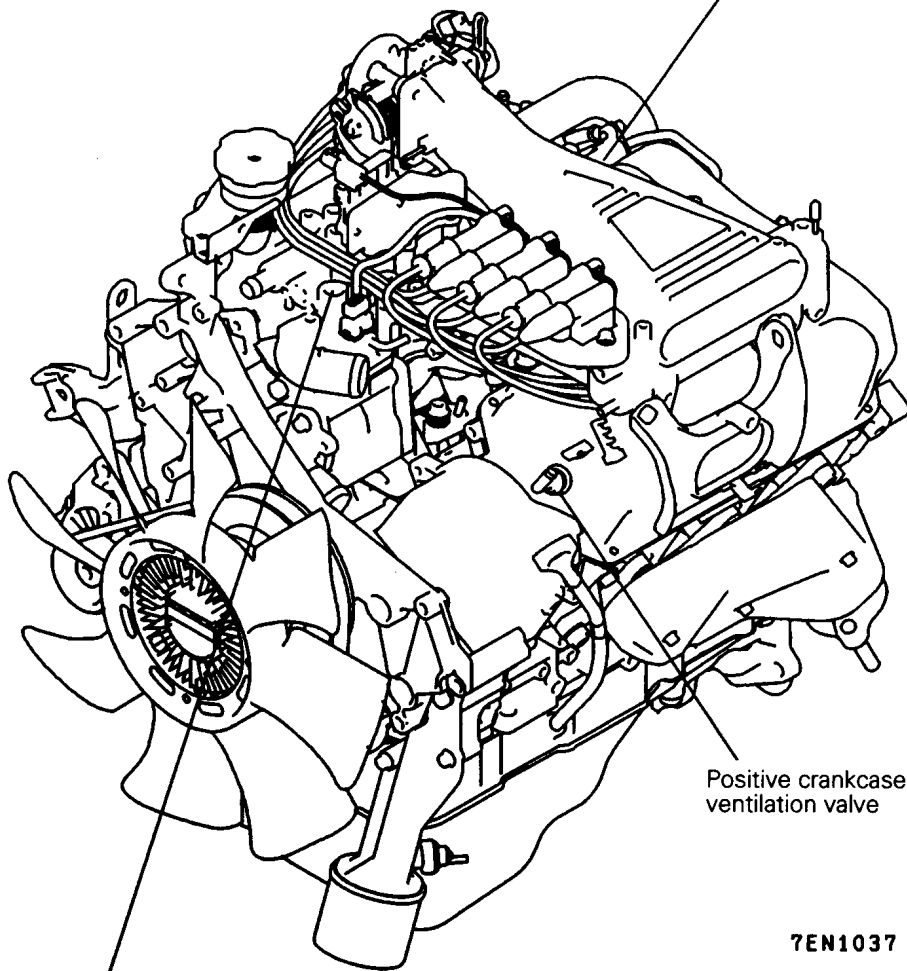
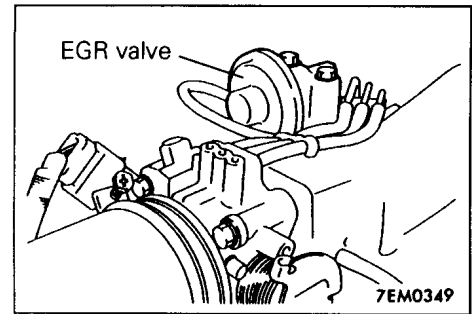

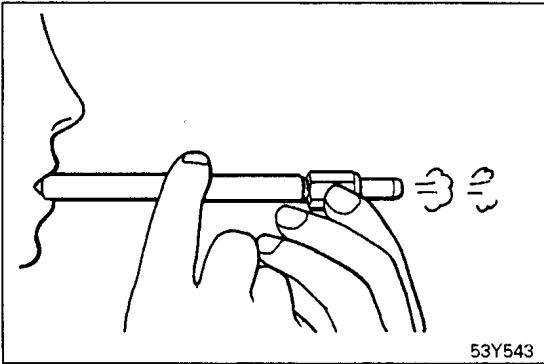

53Y543

3. INSPECTION

POSITIVE CRANKCASE VENTILATION VALVE

- (1) Remove the positive crankcase ventilation valve.
- (2) Blow from the threaded end of the positive crankcase ventilation valve. If you cannot blow through it, the positive crankcase ventilation valve is clogged.
- (3) If the positive crankcase ventilation valve is clogged, clean it with cleaning solvent.
- (4) Install the positive crankcase ventilation valve. (In case of screw-in type, tighten to the specified torque)

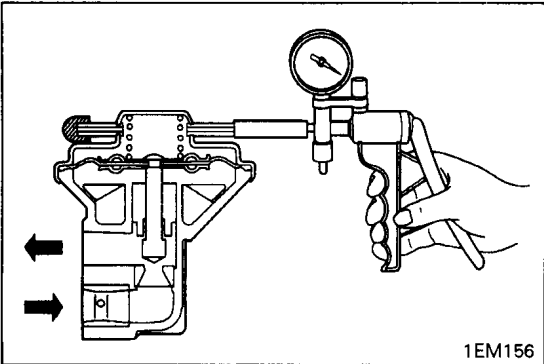

1EM156

EGR VALVE

- (1) Remove the EGR valve and check it for sticking, carbon deposits, etc.
If such conditions exist, clean it adequately with solvent to ensure correct valve seat contact.
- (2) Connect a hand vacuum pump to the EGR valve.

Caution

- **Plug one nipple of the EGR valve.**

- (3) Apply a vacuum of 66.7 kPa (500 mmHg, 19.7 inHg) air tightness.
- (4) Blow air in from one passage of the EGR to check its condition as follows.

Vacuum	Normal condition
2.7 kPa (20 mmHg, 0.8 inHg) or lower	Air does not blow through
40 kPa (300 mmHg, 12 inHg) or higher	Air blows through

- (5) Replace the gasket with a new one and tighten the EGR valve to the specified torque.

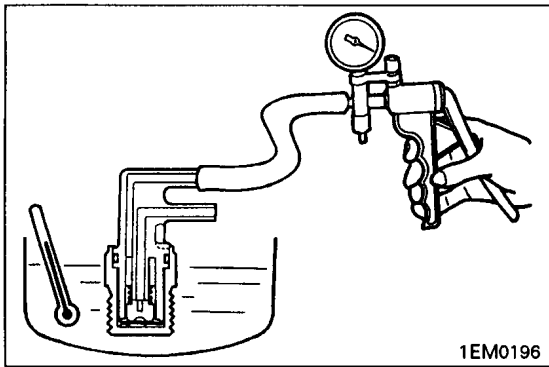

1EM0196

THERMO VALVE

(1) Remove the thermo valve.

Caution

- When removing the thermo valve, do not use wrenches or other tools on the resin part of the valve.

(2) Connect a hand vacuum pump to the thermo valve nipple.
 (3) Immerse the temperature sensing section into water and apply a negative pressure with the hand vacuum pump while heating the water.

Water temperature	Normal condition
10°C (50°F) or lower	Vacuum leaks
80°C (176°F) or higher	Vacuum holds

NOTE

Different engines have different number of thermo valve nipples. Be sure to check all nipples.

(4) If any fault is found when performing the above checks, replace the thermo valve.

(5) Apply sealant to threaded portion.

Specified sealant:

3M Nut Locking No.4171 or equivalent

(6) Install the thermo valve and tighten it to the specified torque.

Caution

- When installing the thermo valve, do not use wrenches or other tools on the resin part of the valve.

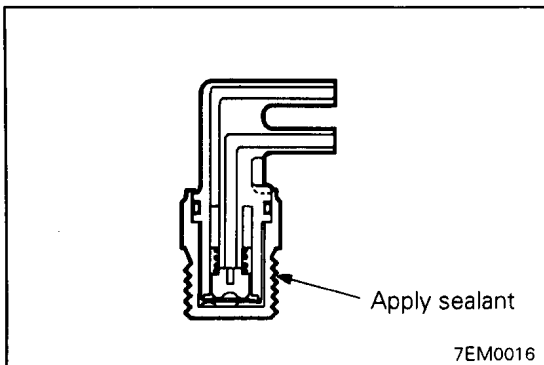

7EM0016

COOLANT TEMPERATURE SENSOR

(1) Remove the coolant temperature sensor from the intake manifold.

(2) Immerse the temperature sensing section in water and measure resistance between terminals 1 and 2 while heating the water.

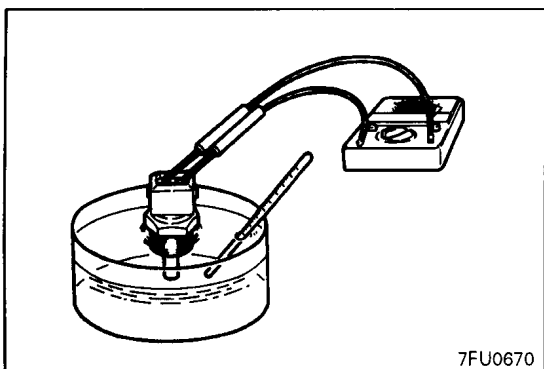

7FU0670

Temperature °C (°F)	Resistance (kΩ)	
	Oval type connector	Square type connector
0 (32)	5.9	5.8
20 (68)	2.5	2.4
40 (104)	1.1	1.1
80 (176)	0.3	0.3

- (3) If the resistance deviates greatly from the standard value, replace the coolant temperature sensor.

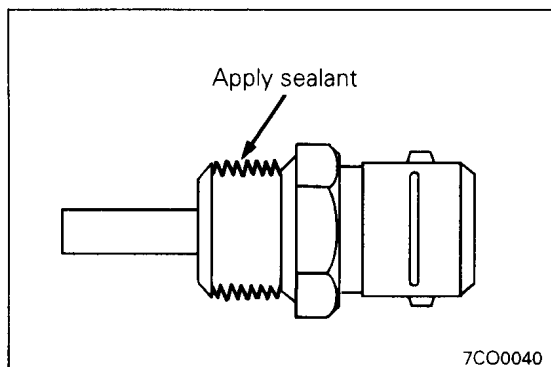

- (4) Apply sealant to threaded portion.

Specified sealant:
3M Nut Locking No. 4171 or equivalent

- (5) Install the coolant temperature sensor and tighten it to the specified torque.